

MODEL 269R

Over & Under 3-Phase Monitor

- Monitors for High Voltage, Low Voltage, Phase Loss & Phase Reversal
- 4 Voltage Ranges
- Automatic Reset
- 5 Year Unconditional Warranty
- Adjustable Restart Delay



DESCRIPTION

The Model 269R Over & Under 3-Phase Monitor continuously monitors 3-phase lines for high voltage, low voltage, phase loss or phase reversal. This device features a solid-state voltage and phase angle sensing circuit, which drives a SPDT output relay.

The Model 269R is independent of the system load, and may be used on any horsepower motor. When phase sequence is correct, and the voltage remains between the upper and lower trip points, the output relay remains energized. When a fault condition is sensed, the output relay drops out.

The Model 269R does not require a neutral connection, and can be used on Wye or Delta systems. Each of the four voltage versions can be adjusted over a wide range. An adjustable restart delay (0.3-5 minutes) allows compressor head pressures to bleed off, in the event of short-term power failures. OVER and UNDER voltage failure indicators aid in calibration and system troubleshooting.

DIMENSIONS

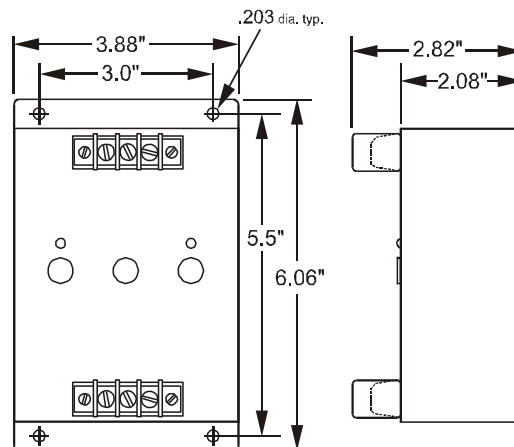

SPECIFICATIONS

| Model | A269R | B269R | C269R | EX269R |
|-------------------------------------|---|------------|------------|------------|
| Nominal AC Voltage (phase to phase) | 120VAC | 208/240VAC | 480VAC | 380VAC |
| Adj Range - Upper | 110 - 145V | 210 - 280V | 400 - 540V | 350 - 450V |
| - Lower | 80 - 115V | 170 - 240V | 380 - 460V | 300 - 400V |
| Frequency | 60Hz | | | 50Hz |
| Power Consumption | 1.5W | 3W | 6W | 6W |
| Transient Protection | 2500VRMS for 10ms | | | |
| Repeat Accuracy | ± 0.1% of set point (fixed conditions) | | | |
| Response Time | 4 ±2 seconds fixed | | | |
| Reset Time | Adjustable 0.3 to 5 minutes | | | |
| Reset Type | Automatic | | | |
| Dead Band | Approximately 2% | | | |
| Output Contacts | SPDT 10A at 240VAC resistive | | | |
| Expected Relay Life | Mech: 10 million operations Elec: 100,000 operations at rated load | | | |
| Operating Temp | - 20° to +130° F | | | |
| Humidity Tolerance | 0-97% w/o condensation | | | |
| Enclosure Material | ABS Plastic | | | |
| Mounting | Surface | | | |
| Weight | 9 oz. | | | |



TIME MARK
CORPORATION

11/2011
© 2011 TIME MARK CORPORATION

TIME MARK is a division of  AEMT, Inc.

MODEL 269R Over & Under 3-Phase Monitor

READ ALL INSTRUCTIONS BEFORE INSTALLING, OPERATING OR SERVICING THIS DEVICE.
KEEP THIS DATA SHEET FOR FUTURE REFERENCE.

GENERAL SAFETY

POTENTIALLY HAZARDOUS VOLTAGES ARE PRESENT AT THE TERMINALS OF THE MODEL 269R .
ALL ELECTRICAL POWER SHOULD BE REMOVED WHEN CONNECTING OR DISCONNECTING WIRING.
THIS DEVICE SHOULD BE INSTALLED AND SERVICED BY QUALIFIED PERSONNEL.

Installation Instructions

INSTALLATION

Rotate both the UNDER VOLTS and MINUTES adjustments counter-clockwise, and OVER VOLTS adjustment clockwise. The 3-phase wiring should be connected to the terminals marked **A**, **B** and **C**.

The control wiring will be connected to the opposite end of the unit, to the terminals with the relay contact markings. The markings printed on the Model 269R are the failed condition of the contacts.

When power is applied to the unit, the TRIP LED indicator should not be lit (the reset switch may have to be pressed on manual reset versions). If the TRIP indicator comes on when power is applied, check that all three phases are present and of the correct voltage. If the voltage is correct, remove power, then reverse two of the three phase wires.

Re-apply power. The TRIP indicator should not be on. After a brief delay (approx. 20 seconds) the contacts will transfer.

ADJUSTMENT SETTINGS

Rotate the UNDER VOLTS adjustment clockwise, until the contacts trip and the UNDER indicator illuminates.

Slowly rotate the UNDER VOLTS adjustment counter-clockwise, until the LED goes out (on manual reset versions, hold the RESET button down while making this adjustment). Rotate the OVER VOLTS adjustment counter-clockwise, until the contacts trip and the OVER trip indicator illuminates. Slowly rotate the OVER VOLTS adjustment clockwise until the LED goes out.

After approximately 20 seconds, the contacts will transfer and the NORMAL indicator will come on. If nuisance trips occur, rotate the VOLTS adjustment slightly farther, counter-clockwise. This method of adjustment will be correct in most cases.

Set the MINUTES delay as required. Application dependent.

TROUBLESHOOTING

Should the Model 269R Monitor fail to operate properly, check that all three voltages are present, and are of the correct voltage level and phase rotation (a Model 108A or 108B Phase Sequence Detector should be used to verify phase rotation). Check all fuses and verify that all wiring connections are correct. If problems persist, contact your local Time Mark Distributor, or the factory for assistance.

TYPICAL APPLICATION

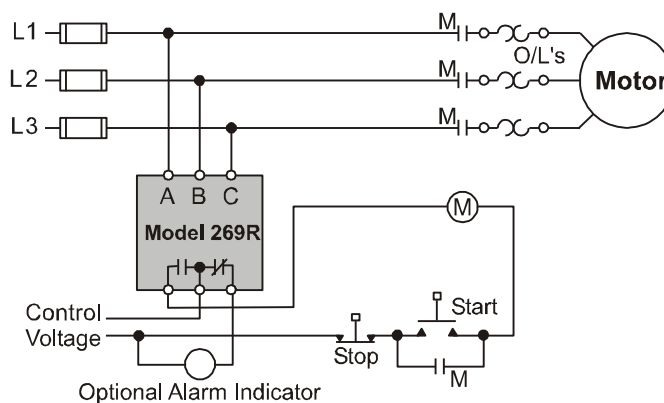

Shows No Power Applied

WARRANTY

This product is warranted to be free from defects in materials and workmanship, and is covered by our exclusive **5-year Unconditional Warranty**. Should this device fail to operate for any reason, we will repair it for five years from the date of manufacture. For complete warranty details, see the *Terms and Conditions of Sales* page in the front section of the Time Mark catalog or contact Time Mark at 1-800-862-2875.



TIME MARK
CORPORATION

11/2011
© 2011 TIME MARK CORPORATION

TIME MARK is a division of  **AEMT, Inc.**